

# ***DRAWWIRE SENSOR***



## **Content:**

<b>Product Description</b>	<b>....2</b>
<b>Technical Data</b>	<b>....3</b>
<b>Dimensions</b>	<b>....4</b>
<b>Installation</b>	<b>....6</b>
<b>Accessories &amp; Order Code</b>	<b>....8</b>

## ***Series SX300***

- Draw wire position transducer for direct attachment to hydraulic cylinders
- Sensor element: digital absolute encoder
- Output signal: SSI, Profibus, CANopen, Profinet, EtherCAT
- pressure up to 300 bar
- measurement ranges up to 15 meters
- unpressurised encoder

## PRODUCT DESCRIPTION

The WayCon SX300 Draw Wire Series is designed for use in combination with hydraulic cylinders and measuring the cylinder position. Especially designed for long stroke cylinders with pressurized housings to be flanged directly to the cylinder head. By giving feed back signals to a machine control unit, it is possible to control the position of a cylinder, to program specific movements or to manage synchronous movements of several cylinders. Due to its small overall size, its short assembly time and its possible customisation, this sensor technology is a cost-effective and flexible solution for a wide range of industrial applications.

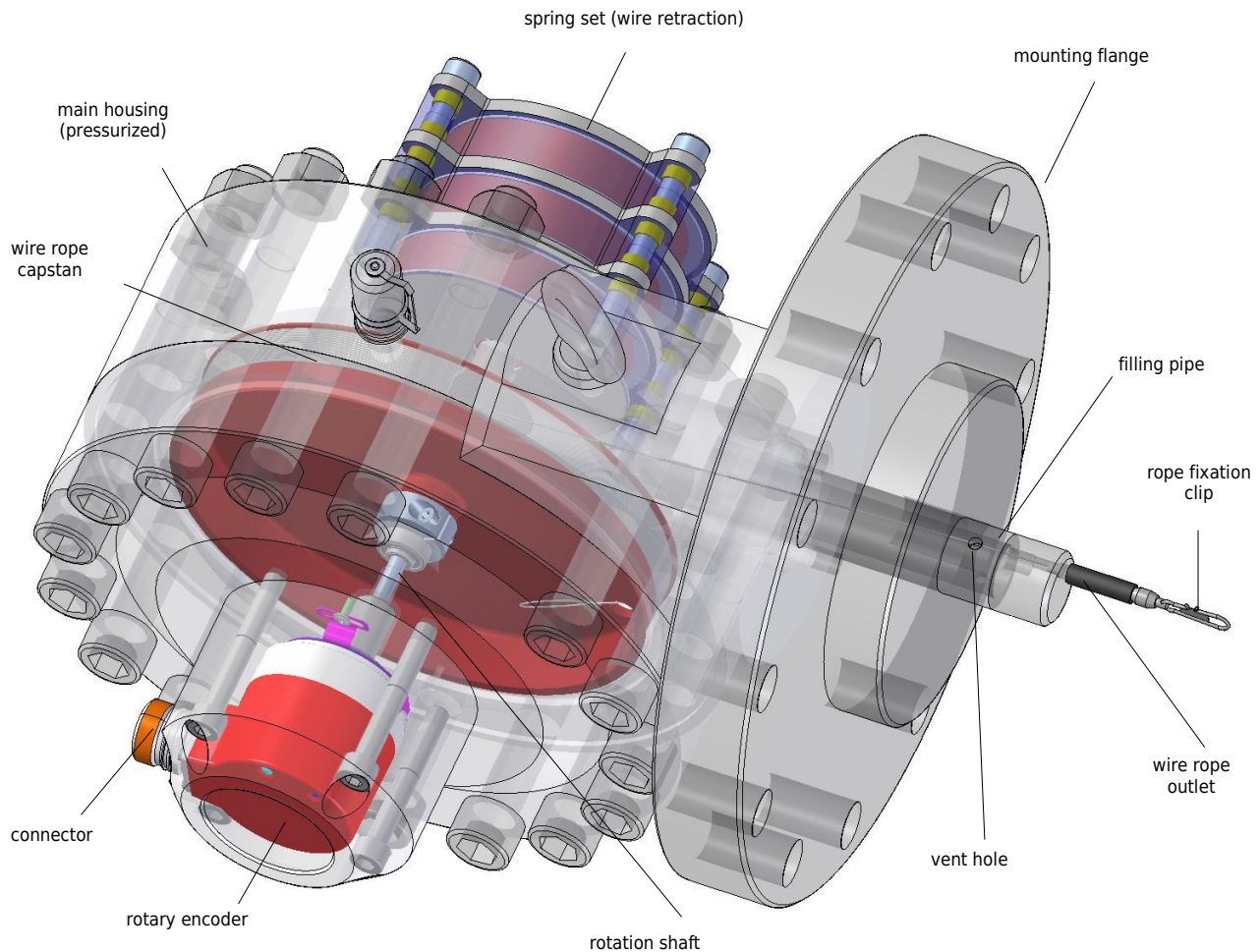

A constant spring force coils the measuring rope accurately single-layered on an wire rope capstan, so that its linear motion is converted into rotation. The sensor element (rotary encoder) provides the output signal required. Due to the dynamics of the draw wire transducer high motion speed and fast acceleration of the cylinder piston can be measured. Its high quality makes applications in harsh industrial environments possible.

## TYPICAL APPLICATIONS

- hydraulic gates for dam control
- synchronous run of more than one cylinder
- sluice gate control
- cylinder acceleration and speed control
- stroke control of fairground ride applications

## TECHNICAL DATA TRANSDUCER

Measurement range	10 m, 15 m
Temperature range	-20...+70 °C
Circumference rope drum	568.9 mm
Linearity	±0.05 %
Pressure port	Minimess 1620
Hydraulic fluid	only non-hazardous fluids (non-flammable, non-toxic), no gaseous media
Operational pressure	30 MPa (300 bar)
Testing pressure	37.5 MPa (375 bar)
Piston travel speed	1 m/s
Piston acceleration	max. 1 m/s <sup>2</sup>
Wire sag (calculated)	<30 mm
Weight	61 kg
Rope tension	start of range: 10...11.5 N (13...16.5 N) end of range: 29...31.5 N (37...43 N)
Encoder type	flange ø 58 mm with stator coupling pitch circle diameter for fixing screws: 63 mm hollow shaft ø 15 mm
Connector orientation	adjustable in 90° steps
Housing material	42CrMo4 (1.7225)
Wire material	stainless steel 1.4301, ø 0.69 mm

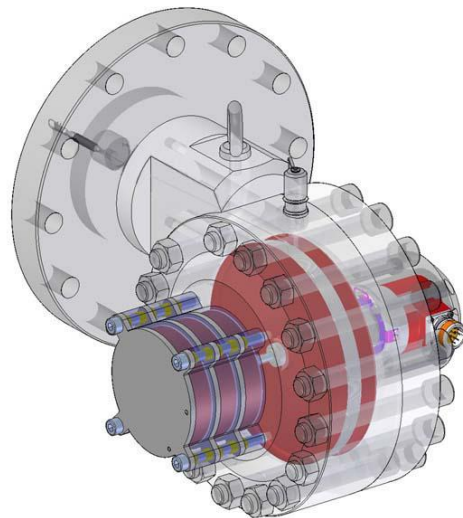

## TECHNICAL DATA ENCODER

		CANopen	SSI	Profibus-DP	EtherCAT	Profinet
Linearity	[%]	0.05, independent of the measurement range				
Resolution scalable (with Software)		yes	no	yes	yes	yes
Standard resolution	[Pulses/mm]	14.4	7.2	14.4	14.4	14.4
	[Bit]	13	12	13	13	13
Maximum resolution	[Pulses/mm]	115.2	-	115.2	115.2	115.2
	[Bit]	16	-	16	16	16
Sensor element		Multiturn-Absolute-Encoder (with optical code disk)				
Connection		cable gland radial	1 x connector M23	cable gland radial	3 x connector M12	3 x connector M12
		2 x	radial, 12 poles	3 x	4 pole, radial	4 pole, radial
Power supply	[VDC]	10...30 (reverse polarity protection of the power supply)				
Current consumption (no load, 24 V)	[mA]	max. 100	max. 50	max. 120	max. 120	max. 200
Protection class		IP65, optional IP67				
Humidity		max. 90 % relative, no condensation				
Temperature	[°C]	-20...+80				
Housing		aluminium, titanium-grey anodised, spring case PA6				
Special cables needed		yes	yes	yes	yes	yes

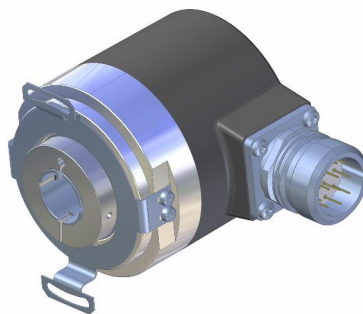

# DIMENSIONS

## Dimensions - flange type F1 (rod sealing type)

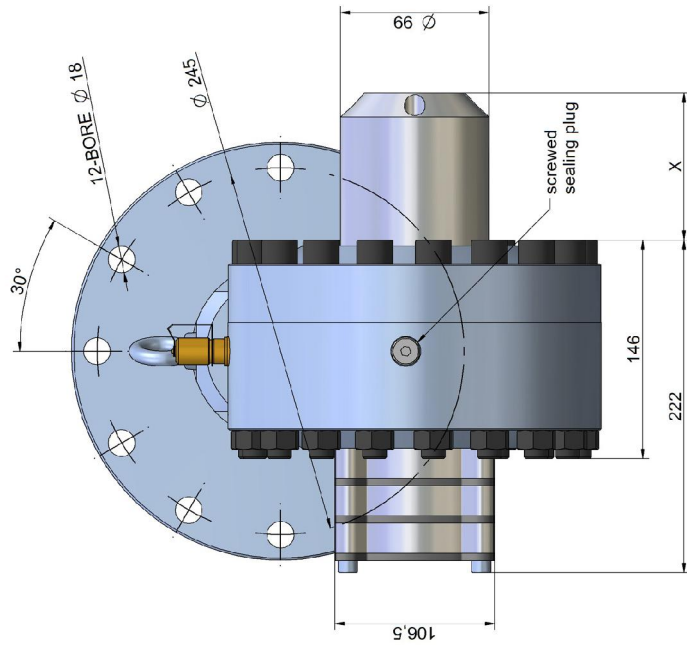

encoder cap:  
 for SSI Encoder: X = 71 mm  
 for Profibus Encoder: X = 98 mm  
 for EtherCAT encoder: X = 98 mm  
 for CANopen encoder: X = 98 mm  
 for Devicenet encoder: X = 100 mm

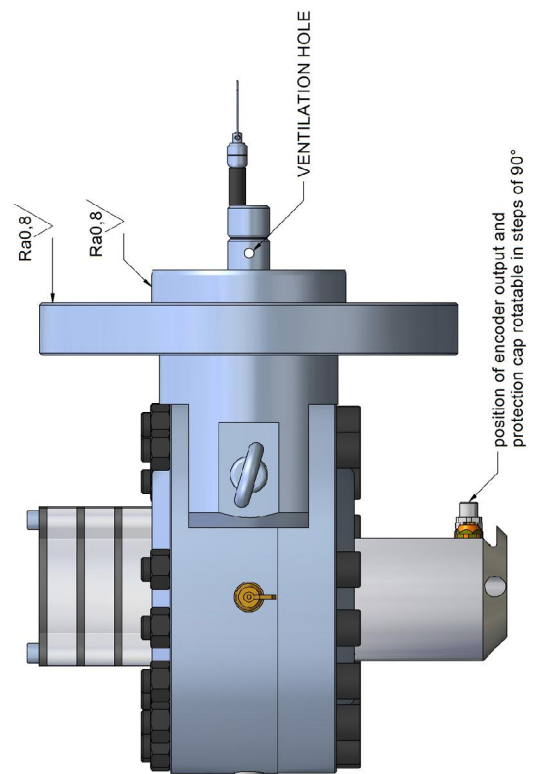
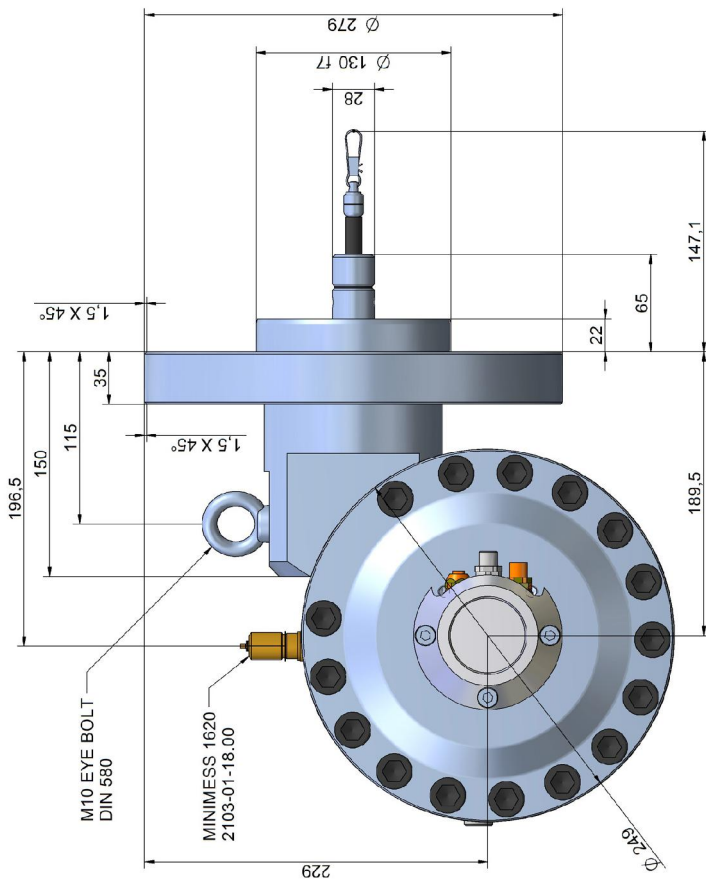
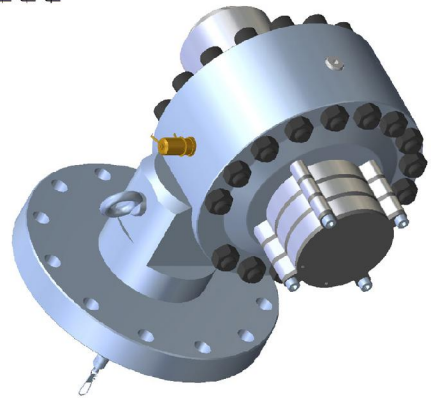



# DIMENSIONS

## Dimensions - flange type F2 (piston sealing type)

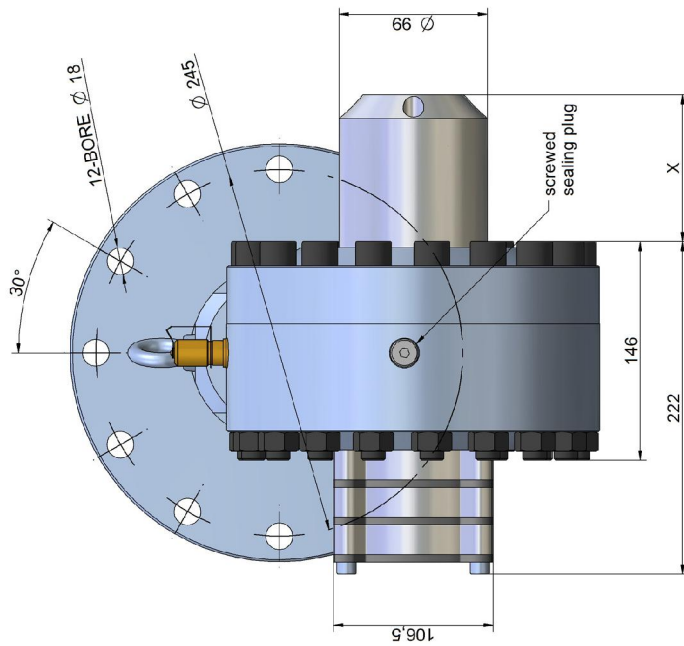

encoder cap:  
 for SSI Encoder: X = 71 mm  
 for Profibus Encoder: X = 98 mm  
 for EtherCAT encoder: X = 98 mm  
 for CANopen encoder: X = 98 mm  
 for DeviceNET encoder: X = 100 mm

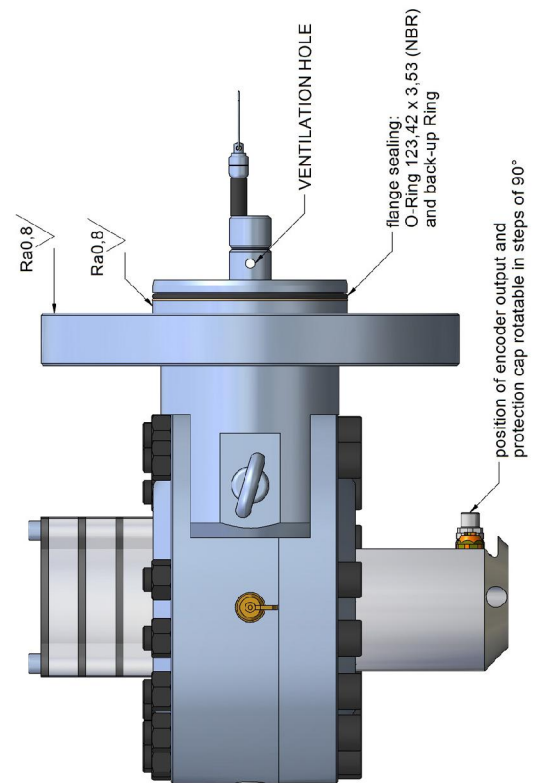
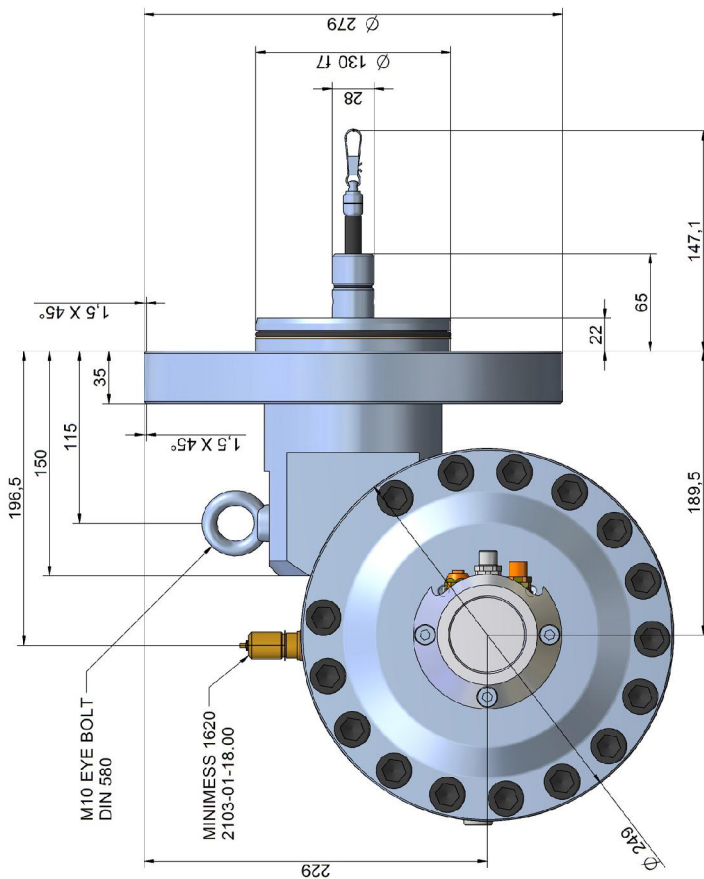
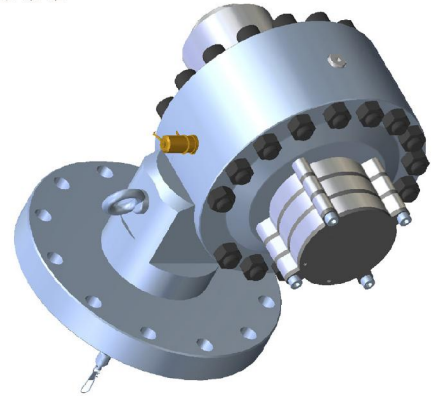

## INSTALLATION

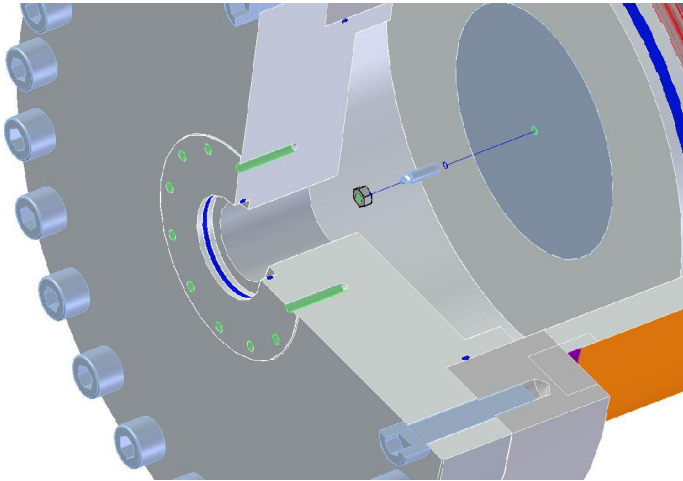

The wire fixation unit has to be screwed into the piston of the cylinder and locked with counter nut.

**Note: use screw locking device. If it is not possible to work through the cylinder head bore, you have to take off the cylinder head (please refer to the cylinder manual).**

*(Drawing contains o-ring (blue) installed in cylinder head bore. This is not necessary! The SX300-...-F2 already features a o-ring sealing on its flange.)*

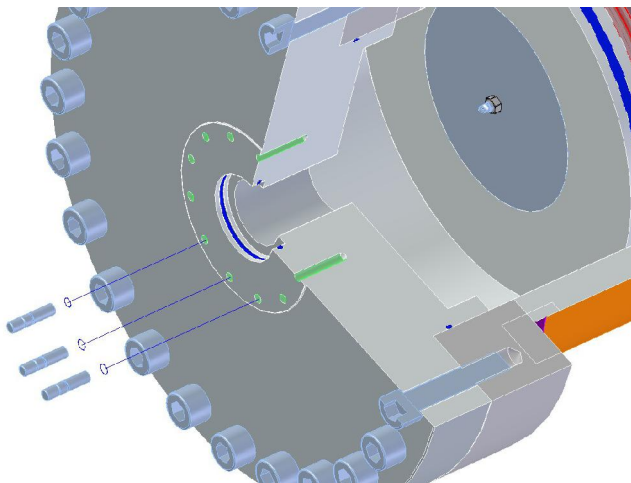

Install 3 stud bolts at the cylinder head.

At the bottom side of the transducer flange, 3 stud bolts are necessary, where no standard bolts can be feed through the bores. Please refer to your installation drawing about the position of the transducer.

**Note: stud bolts greased with MoS2 if not defined otherwise in the cylinder manual. Please refer to the cylinder manual.**

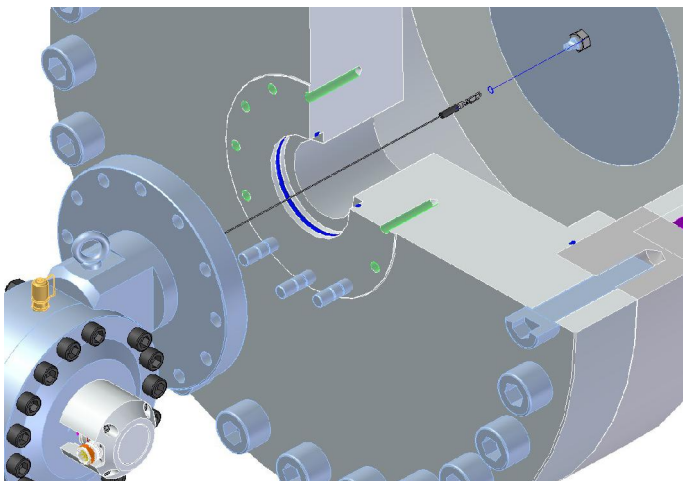

Move transducer nearby the cylinder head bore (use lifting device e.g. crane). Remove the protection cap above the wire outlet. Open the clip (carabiner) and feed the wire through the bore. Hook in the clip into the wire fixation and close the interlock snap.

**Note: Don't let the rope snap back. If the rope is retracted freely, this may lead to injuries and the transducer may be damaged. Caution when unhooking and retracting the rope into the sensor. Avoid guiding the rope over edges or corners.**

## INSTALLATION

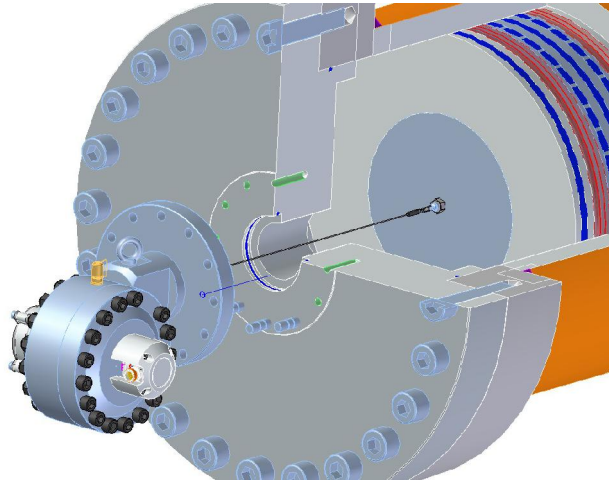

Move the transducer to the cylinder head and feed the stud bolts through the flange bores.

**Note:** Avoid guiding the rope over edges or corners. Be aware of the o-ring and refer to the cylinder manual. Don't operate the transducer if the rope is buckled or damaged. A ripping of the rope may lead to injuries or damaging the transducer.

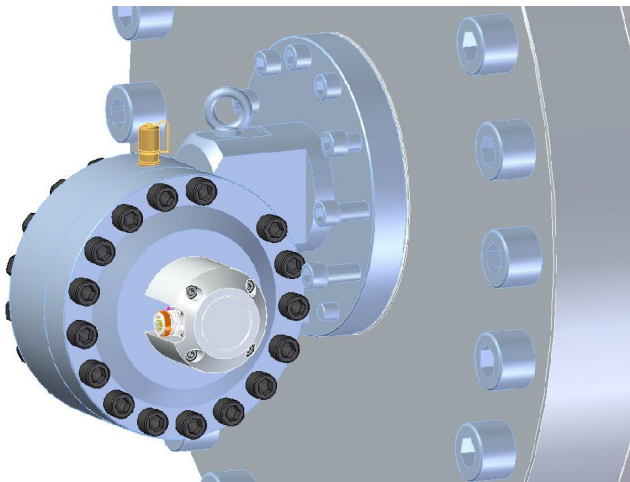

Screw tightly the bolts through the flange. Tighten crosswise to a first torque of about 100 Nm.

**Note:** bolts greased with MoS2 if not defined otherwise in the cylinder manual. Please refer to the cylinder manual.

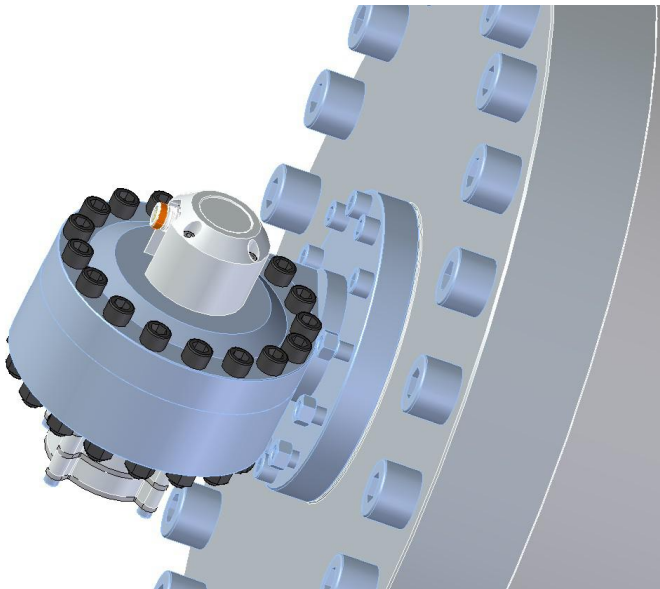

Screw tightly the nuts onto the stud bolts at the bottom side of the transducer. Tighten bolts and nuts crosswise to the specific torque. If not otherwise stated in the cylinder manual, apply torque as follows:

- 145 Nm for M16 quality 8.8
- 215 Nm for M16 quality 10.9
- 250 Nm for M16 quality 12.9

**Note:** nuts greased with MoS2 if not defined otherwise in the cylinder manual. Please refer to the cylinder manual.

# ACCESSORIES

## Piston wire fixation

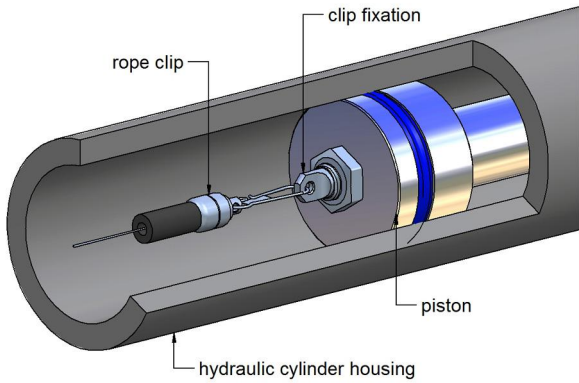

### Clipfixation M8

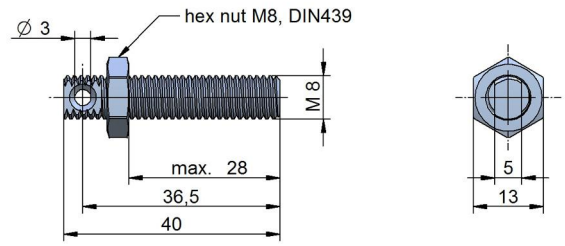

### Clipfixation M14

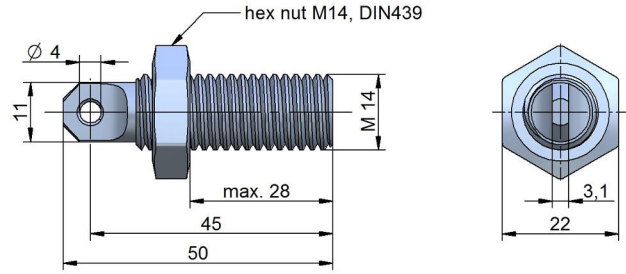

# ORDER CODE

SX300 - [ ] - [ ] - [ ]

Measurement Range	
10 meter	10
15 meter	15
Other measurement ranges on request.	

Transducer with encoder	
SSI	SSI
Profibus-DP	PRO
CANopen	CAN
Profinet	NET
EtherCAT	CAT
Transducer without encoder *	
draw wire mechanics, for encoder assembly	H15/63

Flange type	
F1	rod sealing type
F2	piston sealing type

\* Encoder requirements:  
 flange Ø 58 mm with stator coupling, pitch  
 circle diameter for fixing screws: 63 mm,  
 hollow shaft Ø 15 mm

Subject to change without prior notice.

## WayCon Positionsmesstechnik GmbH

email: [info@waycon.de](mailto:info@waycon.de)  
 internet: [www.waycon.de](http://www.waycon.de)

## Head Office

Mehlbeerenstr. 4  
 82024 Taufkirchen  
 Tel. +49 (0)89 67 97 13-0  
 Fax +49 (0)89 67 97 13-250

## Office Köln

Auf der Pehle 1  
 50321 Brühl  
 Tel. +49 (0)2232 56 79 44  
 Fax +49 (0)2232 56 79 45