

CAPACITIVE SENSORS

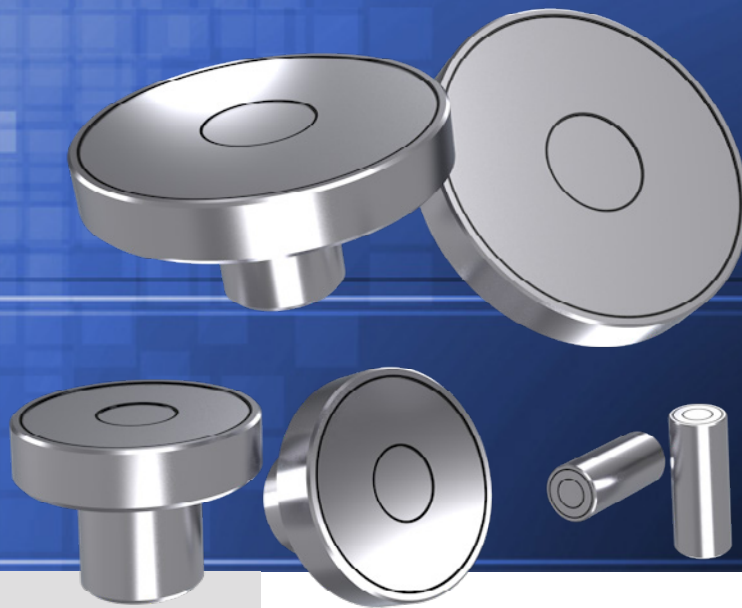

Content:

Introduction2
Technical Data Sensor Heads3
Technical Data Electronics4
Description Electronics6
Technical Drawing7
Cables8
Order Code9

Series KS

Key-Features:

- extremely high resolution (Nanometer)
- Measurement ranges 50 μ m up to 10 mm
- Accuracy is independent of temperature
- Temperature range -50 to +200 °C, custom probes up to +450 °C
- High class electronics, one or multi-channel
- Cost effective electronics KL
- Analog output 0...10 V
- Protection class sensors up to IP68
- Reliable measurements even in extreme environments, like nuclear radiation, high vacuum or near 0 K
- Customized probes feasible

INTRODUCTION

The design of the WayCon capacitive sensors is based on the fact that the reactance of an ideal plate capacitor is proportional to the distance between the plates.

The measurement sensor is a guard ring capacitor, whose guard ring is connected to the inner shield of the double shielded measuring cable. A negative feedback amplifier keeps this protective shield tuned exactly to the potential of the sensor centre electrode. This ensures an almost homogeneous field between the capacitor plates along the entire measuring range and nearly complete independence of changes in cable capacity. If an alternating current of constant amplitude and frequency passes through the sensor capacitor, the amplitude of the alternating voltage between the capacitor plates (electrode of sensor and object to be measured) is proportional to the distance between the two. The sensor's power supply as well as a compensating voltage which can be selected by means of a precision potentiometer is provided by a 20-kHz-oscillator of highly constant amplitude and frequency. Through a low-pass filter and an amplifier the voltage difference is conducted towards the output terminal.

As described in the above section the measurement of the distance meter is affected by the properties of the dielectric. Generally, the sensor will be used for measurements in air. The area between the sensor and the target should be completely free of dust, oil or water. If necessary, this can be achieved by blowing air through the gap between sensor and target.

Influence of temperature

The main temperature influence is the longitudinal elongation of the sensor material. Customised versions made of INVAR are available on request. The maximum operating temperature is limited by the melting temperature of the soldering material inside the connector.

Measurements at extremely low temperatures, close to the absolute zero, were successfully conducted with our standard probes (Fa. Dornier, FZ Karlsruhe, ETH Zürich).

Measurements in liquids

When carrying out measurements in liquids, which should only be done in special cases, one should consider that the measurements are not only affected by impurities but also by gas bubbles. The real distance is found by multiplying the distance (provided by the meter) with the dielectric constant (epsilon) of the fluid. Please also consider that generally the dielectric constants of liquids are temperature dependent and that the dielectric losses of the liquids used must be negligible, i.e. the liquids must be insulating.

Magnetic fields

Magnetic fields can be neglected, as long as there is no exertion of force to the measurement system. On request the sensor heads can be made of non-magnetic material, like Titanium.

Radioactive radiation

Radioactive radiation has no influence on measurements performed by capacitive sensors. Appropriate insulation materials guarantee long term operation, without failure.

Specific resistance

The relatively low carrier frequency of the system allows measurement at materials in the micro ohm to kilo ohm range ($\mu\Omega$ cm up to $> 1000 \Omega$ cm) without special recalibration. This also covers the entire range of the semiconductor silicon.

This fact is of great importance when measuring on case-hardened shafts in the mechanical engineering sector. This is because an inhomogeneous micro-structure has no influence on the measurement results. There is almost no other method to control the displacement of a shaft running in oil in a sliding bearing than by a capacitive sensor.

Measurements on insulation material

The capacitive sensors can also be used to measure the thickness of non-conductive materials such as plastics, foils, quartz, glass, ceramics, etc.

Averaging

The sensors active area measures the average distance to the object. The roughness of an objects surface is automatically averaged by the system. This feature is of advantage when small irregularities should not be observed. The average distance is also measured in cases where the target has a curved surface.

Customised probes (sensor heads)

No other measurement principle allows for such cheap and simple adaptations of the probe housing or the active area according to the customer needs. The reason for this is the pure mechanical construction consisting of conducting electrodes and insulating barrier sheets (plastics, ceramics, glass).

APPLICATION EXAMPLES

- Dynamic measurement on turbines and motors
- Offset and wear measurement on bearings
- Concentricity measurement on axes, shafts and bores
- Measurement of modulus of elasticity and thermal expansion
- Distance measurement in the low temperature range and high temperature range up to 450 °C
- Reference system for other distance sensors
- Tolerance verification in mass production
- Vibration measurements
- Elongation measurements
- Thickness measurement and control of thin metal foils and plastic foils, also during production
- Measurement of thickness, bevel and deflection of wafers in semiconductor production



The worlds smallest capacitive sensor

TECHNICAL DATA - STANDARD SENSORS

		K0005	K0020	K0050	K0100	K0200	K0300	K0500	K1000
Measurement range	[mm]	0.05	0.2	0.5	1	2	3	5	10
Linearity ¹⁾	[%]	±0.2							
Resolution dynamic ¹⁾	[%]	0.01							
Sensitivity	[µm/V]	5 ±0.2%	20 ±0.2%	50 ±0.2%	100 ±0.2%	200 ±0.2%	300 ±0.2%	500 ±0.2%	1000 ±0.2%
Tolerance of sensitivity ²⁾	[%]	±2	±1	±0.5					
Temperature error sensitivity	[x10 ⁻⁶ /K]	-3	-0.3	-11	-1.1	-3			
Coefficient of thermal expansion	[µm/K]	0.03		0.06			0.17		
Operating temperature	[°C]	-50...+200							
Diameter active area	[mm]	1.1	2.3	3.8	5.5	7.9	9.8	12.6	17.7
Minimum target diameter	[mm]	3	6	7	9	17	27	37	57
Connection cable ³⁾		L13-12, L13-14, L33-12, L33-14				L13-11, L13-13, L33-11, L33-13			
Weight	[g]	1.7	2.5	5.7	7.1	61	95	120	230
Housing material (DIN EN 10027-2)		1.3912		1.4104			1.4305		

¹⁾ depending on the connected electronics

²⁾ manufacturing tolerance

³⁾ only use listed cables. For more information see section „Cables“.

SENSOR HEAD EXAMPLES

Standard sensors



Custom sensors examples



TECHNICAL DATA - 1-CHANNEL ELECTRONICS

		KL	KL3M	K1	KS1
Number of channels		1			
Linearity ¹⁾ (at 0...40 °C, dielectric: air)	[%]	<±0.4	±0.2	±0.1	±0.2
Repeatability	[%]	0.02 ²⁾		±0.05 ¹⁾	
Sampling rate	[kHz]	0.5		4.5	
Display		-		4.5 digits	
Power supply		100...240 V, 50 Hz / 60 Hz		115 V, 60 Hz / 230 V, 50 Hz	
Power consumption	[VA]	5		9	18
Operating temperature	[°C]	0...+70	0...+85	0...+50	
Storage temperature	[°C]	-20...+80	-20...+90	-20...+70	
Warm up time	[min]	3		30	
Weight	[kg]	0.35	0.7	3.7	4
Dimensions (W x H x D)	[mm]	64 x 35 x 115	80 x 60 x 170	180 x 150 x 265	260 x 150 x 265
Upgradable to multi-channel		no			yes
Housing construction		aluminium die-cast		19" system, 3 HE	
Amplifier with trimming potentiometer		no		yes	no
Voltage output		„OUT“		„NORM“	„OUT“
Sensitivity ³⁾		10 V/mm ±0.2%			
Linearity	[%]	<±0.4	±0.2		
Temperature error sensitivity	[%/°C]	<0.02	<0.01		
Temperature drift offset (U _a = 0 V)	[mV/°C]	-		<±0.3	
Long term drift offset (U _a = 0 V)		-		<±1 mV/week, <±10 mV/year	
Output voltage max.		±10 V			
Output current max.		±5 mA			
Frequency dependency		0...500 Hz (-3 dB)		0...4 kHz: ±1 % / 0...6 kHz: -3 dB	
Noise		<10 mV _{pp}		U _a = 0 V: <5 mV _{pp} typ. 2 mV _{pp} / U _a = 10 V: <10 mV _{pp}	
Connector		LEMO		BNC	
Additional output ⁴⁾		-		„VARI“	-
Sensitivity factor		-		0...10	-

¹⁾ based on the measurement range

²⁾ based on the resolution

³⁾ These specifications are valid for the use of the probe K0100 (measurement range 0...1000 µm). The display and its labelling are designed for 0...1000 µm. All other probes may also be used with the electronics. The reading has to be converted with an integer factor according to the used probe.

⁴⁾ U_a = 0 V: The output voltage can be adjusted to zero over the full scale by using the potentiometer. By doing this the influence of drift, temperature and noise are the smallest (= compensation method). Especially during long-term measurement with small value changes this method is recommended.

TECHNICAL DATA - MULTICHANNEL ELECTRONICS

		KS2	KS3	KS4	KS5	KS6	KS7	KS8
Number of channels		2	3	4	5	6	7	8
Linearity ¹⁾ (at 0...40 °C, dielectric: air)	[%]	±0.2						
Repeatability ¹⁾	[%]	±0.05						
Sampling rate	[kHz]	4.5						
Display		4.5 digits						
Power supply		115 V, 60 Hz / 230 V, 50 Hz						
Power consumption	[VA]	18	22.7	27.3	32	36.7	41.3	46
Operating temperature	[°C]	0...+50						
Storage temperature	[°C]	-20...+70						
Warm up time	[min]	30						
Weight	[kg]	4	4.7	5.3	6	6.7	7.3	8
Dimensions (W x H x D)	[mm]	260 x 150 x 265	295 x 150 x 265	330 x 150 x 265	365 x 150 x 265	400 x 150 x 265	435 x 150 x 265	470 x 150 x 265
Housing construction		19" System, 3 HE						
Voltage output		„OUT“						
Sensitivity ²⁾		10 V/mm ±0.2%						
Linearity	[%]	±0.2						
Temperature error sensitivity	[%/°C]	<0.01						
Temperature drift offset (U _a = 0 V)	[mV/°C]	<±0.3						
Long term drift offset (U _a = 0 V)		<±2 mV/week, <±20 mV/year						
Output voltage max.		±10 V						
Output current max.		±5 mA						
Frequency dependency		0...4 kHz: ±1 % / 0...6 kHz: -3 dB						
Noise		U _a = 0 V: <5 mV _{pp} typ. 2 mV _{pp} / U _a = 10 V: <10 mV _{pp}						

¹⁾ based on the measurement range

²⁾ These specifications are valid for the use of the probe K0100 (measurement range 0...1000 µm). The display and its labelling are designed for 0...1000 µm. All other probes may also be used with the electronics. The reading has to be converted with an integer factor according to the used probe.

DESCRIPTION ELECTRONICS



KL / KL3M



K1



KS2



KS8

DESCRIPTION ELECTRONICS

Features

The device measures, without contact, the distance between the front side of the sensor and the conductive surface of the target. Sensor and target form an electrical capacitor. The device is calibrated in length units. It includes a display and a compensator with digits. Therefore, static measurements with the compensation method as well as the deflection method are possible. An outlet provides a voltage value proportional to the distance for static and dynamic measurements. The zero point of the output voltage may be accurately shifted by means of the compensator.

Construction and working principle

The design of the KS electronics is based on the fact that the reactance of an ideal plate capacitor is proportional to the distance between the plates. The measurement sensor is a guard ring capacitor, whose guard ring is connected to the inner shield of the double shielded measuring cable. A negative feedback amplifier keeps this protective shield tuned exactly to the potential of the sensor's centre electrode. This ensures an almost homogeneous field between the capacitor plates along the entire measuring range and nearly complete independence of changes in cable capacity. If an alternating current of constant amplitude and frequency passes through the sensor capacitor, the amplitude of the alternating voltage between the capacitor plates (electrode of sensor and object to be measured) is proportional to the distance between the two. The sensor's power supply as well as a compensating voltage which can be selected by means of a precision potentiometer is provided by a 20-kHz-oscillator of highly constant amplitude and frequency. The sensor voltage and the compensating voltage are rectified by means of a rectifier with high linearity and zero stability. Through a low-pass filter and an amplifier the voltage difference is conducted towards the output terminal. The display shows the distance between the object to be measured and the front side of the sensor.

As described in the above section the measurement of the distance meter is affected by the properties of the dielectric. Generally, the sensor will be used for measurements in air. The area between the sensor and the target should be completely free of dust, oil or water. If necessary, this can be achieved by blowing air through the gap between sensor and target.

Typical applications

The KS system can be used to measure shaft movements in bearings, rotor vibrations, the smoothness of running of machine tools, static and dynamic deformations, vibrations in a plane, module of elasticity, coefficient of thermal expansion, circularity of shafts and bore holes and so on.

Changing the sensor head

Due to the small sensitivity tolerances of the sensors it is possible to exchange sensors without recalibrating the KS electronics. A total accuracy of $\pm 0.5\%$ is still guaranteed.

Additional output

For special applications the sensitivity of the output voltage may be adjusted by a factor 0 to 10 (Socket "VARI." and adjustment by "FACTOR").

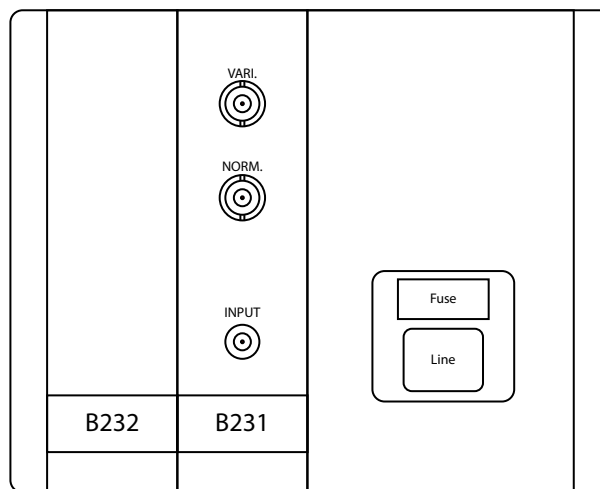

back side KS1

TECHNICAL DRAWING - SENSOR HEADS

<p>K0005</p> <p>Dimensions: $12^{+0}_{-0.1}$, 5, $\varnothing 6 e7$, $\varnothing 6 h6$</p> <p>Einspannbereich</p>	<p>K0020</p> <p>Dimensions: $12^{+0}_{-0.2}$, 5, $\varnothing 6 e7$, $\varnothing 6 h6$</p> <p>Einspannbereich</p>	<p>K0050</p> <p>Dimensions: $20^{+0}_{-0.2}$, $\varnothing 8 h7$</p>
<p>K0100</p> <p>Dimensions: $20^{+0}_{-0.2}$, 11, $\varnothing 10 e7$, $\varnothing 10 h6$</p> <p>Einspannbereich</p>	<p>K0200</p> <p>Dimensions: $30^{+0}_{-0.2}$, $\varnothing 20 h7$</p>	<p>K0300</p> <p>Dimensions: $30^{+0}_{-0.2}$, 20, $\varnothing 30 h7$, $\varnothing 20 h7$</p>
<p>K0500</p> <p>Dimensions: $30^{+0}_{-0.2}$, 20, $\varnothing 40 h7$, $\varnothing 20 h7$</p>		<p>K1000</p> <p>Dimensions: $30^{+0}_{-0.2}$, 20, $\varnothing 60 h7$, $\varnothing 20 h7$</p>

TECHNICAL DRAWING - ELECTRONICS

<p>KL</p> <p>Dimensions: 64, 11, 14.2, 9.6, 7.25, 2.45, 115, 34.5, 105, 56, $\varnothing 4.5$</p> <p>OUTPUT, SUPPLY, SENSOR</p>	<p>KL-3M</p> <p>Dimensions: 28, 11, 12, 175, 55, 78</p>
---	--

CABLES

Attention: The cable is part of the resonant circuit and must therefore not be shortened, bent or changed in any other way. The cable is a specially manufactured triaxial-cable, designed for best measurement results. Please use original cables only.

Cable	L13-11	L13-12	L13-13	L13-14	L33-11	L33-12	L33-13	L33-14
Length	1 m				3 m			
Cable diameter	3 mm							
Operating temperature	-50...+150 °C							
For sensor heads	K0100 K0200 K0300 K0500 K1000	K0005 K0020 K0050	K0100 K0200 K0300 K0500 K1000	K0005 K0020 K0050	K0100 K0200 K0300 K0500 K1000	K0005 K0020 K0050	K0100 K0200 K0300 K0500 K1000	K0005 K0020 K0050

L13-11, L33-11

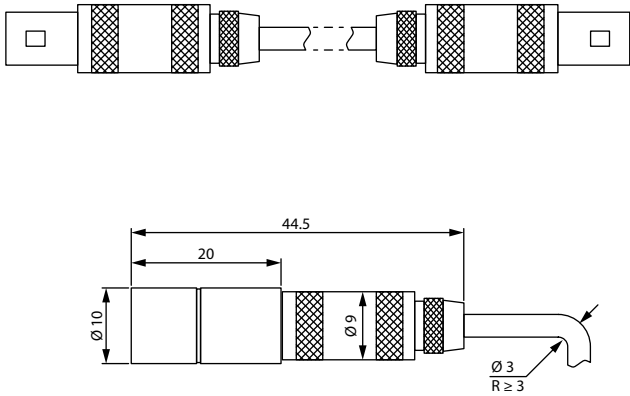

dimensions with K0100

L13-12, L33-12

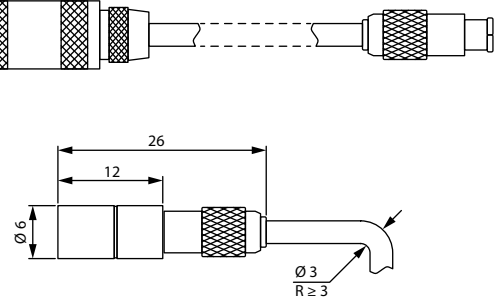

dimensions with K0020

L13-13, L33-13

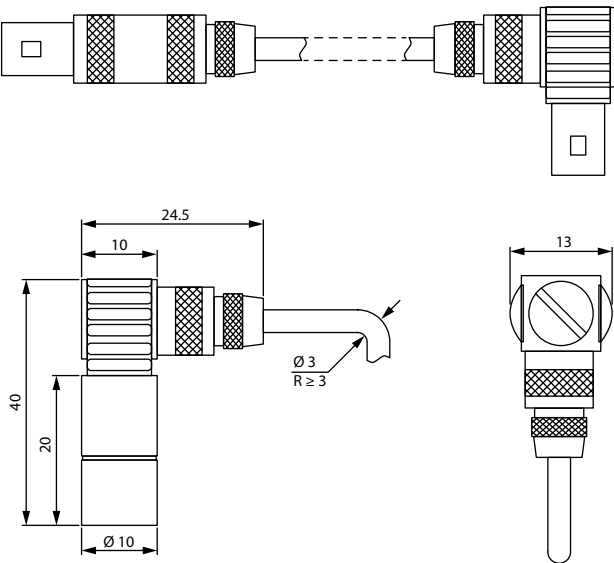

dimensions with K0100

L13-14, L33-14

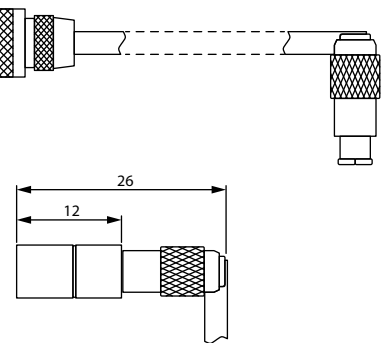

dimensions with K0020

ORDER CODE

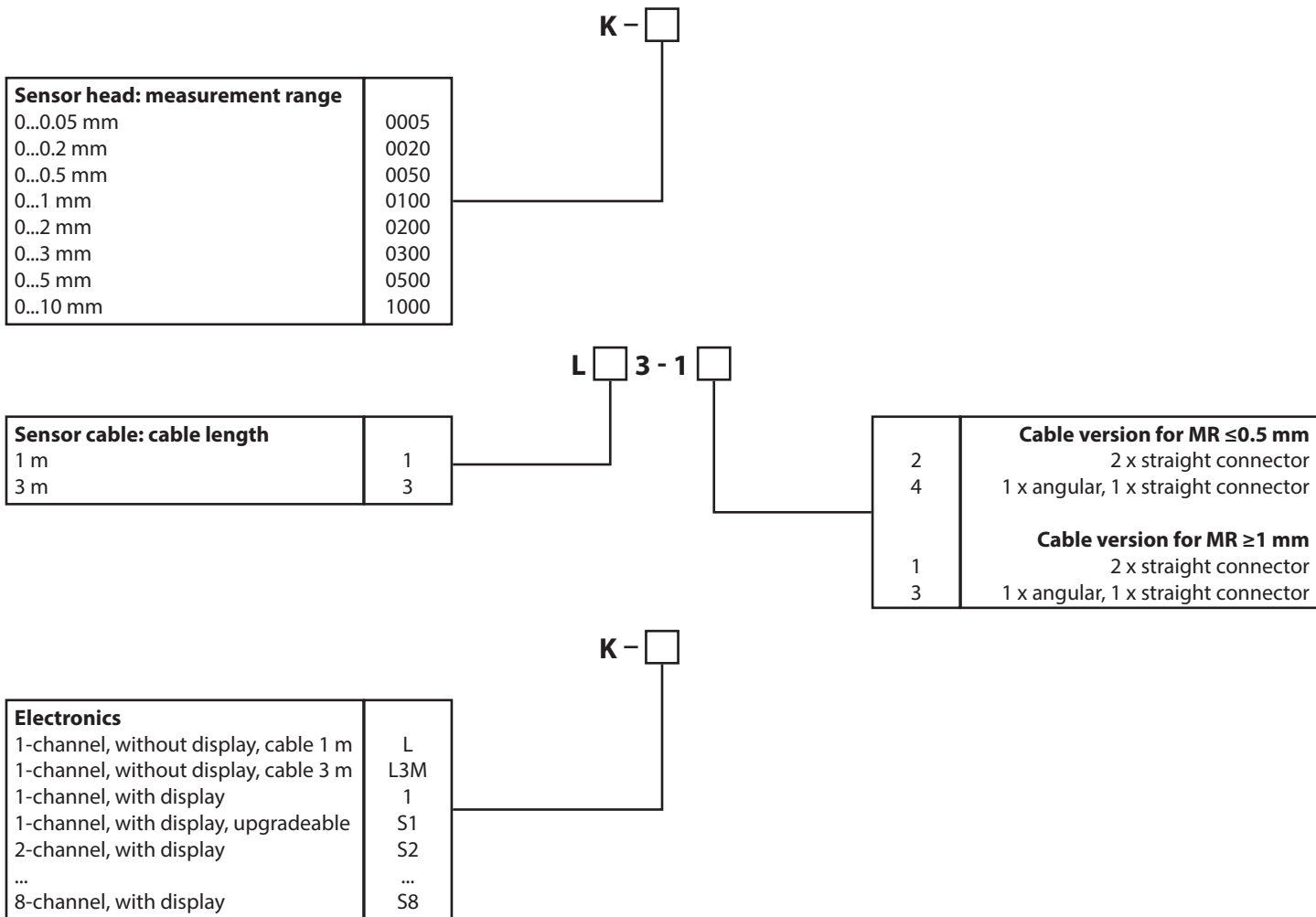

The scope of delivery of the KL and KL3M electronics includes a 4 m output cable. This is in addition to the 1 m or 3 m supply cable.

Subject to change without prior notice.

WayCon Positionsmesstechnik GmbH
 email: info@waycon.de
 internet: www.waycon.biz

Head Office
 Mehlarstr. 4
 82024 Taufkirchen
 Tel. +49 (0)89 67 97 13-0
 Fax +49 (0)89 67 97 13-250

Office Köln
 Auf der Pehle 1
 50321 Brühl
 Tel. +49 (0)2232 56 79 44
 Fax +49 (0)2232 56 79 45



Positionsmesstechnik