

LASER

Analog Laser Displacement Transducer



Series LAV

Key-Features:

- Measurement ranges 0.2 to 8.0 and 0.2 to 50.0 m
- Absolute accuracy ± 25 mm
- Repeatability <5 mm
- Response time 10 ms
- Individual parametrization by teach-in procedure
- Protection class IP65
- Working temperature -30 to 50 °C
- Analog output 4..20 mA
- IO-Link Interface

Content

Measurement Principle & Installation2
Technical Data3
Electrical Connection3
Technical Drawing4
Teach-In5
Order Code6

INTRODUCTION

LAV laser sensors cover measurement ranges from 0.2 to 50.0 m. The integrated micro-controller delivers an accurate output signal, which is proportional to the detected distance. External analysers to evaluate the signals are not required. Reliable operation, independent of colour or other influences of the surface, is ensured by sophisticated electronic elements integrated in the system. The small visible laser spot allows a simple and precise orientation of the sensor.

MEASURING PRINCIPLE

A powerful light source emits short, high-energy pulses, which are reflected by the target object and then recaptured by a light-sensitive receiver. During this process, the emission and reception times are detected with a high degree of precision. From the values determined, the distance to the target object is calculated using the runtime of the light pulses. If the target object is close, the light propagation time is short. If the object is further away, the light propagation time is longer.

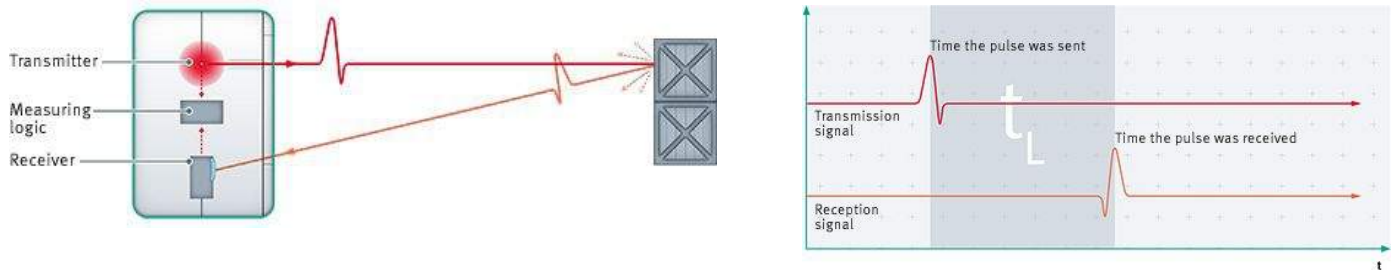

GENERAL NOTES

Teach-in function

The desired range can conveniently be adapted within the maximum measurement range by means of the teach-In button. The analog output has its full stroke within the teach-ed range. The default configuration uses the maximum measurement range. A description of the teach-in procedure can be found on page 5 of this data sheet.

Installation

The first condition for a successful distance measurement is the absence of any obstruction in the light path, as shown in fig. 3. The receiver optics must be able to detect the light spot directly (fig. 1 and 2).

For highly polished or mirror-like objects it is important to keep the direct reflection away from the detector. In these cases, it is recommended to slightly tilt the sensor (fig. 4).

Optimum results are obtained by transverse installation of the sensor with respect to the target movement (fig. 5).

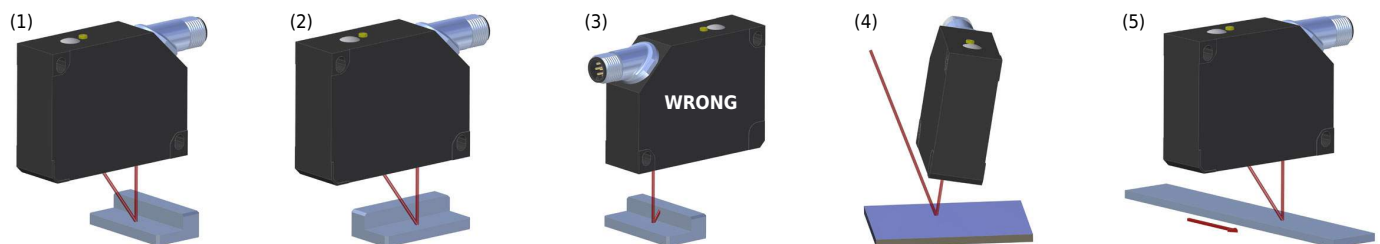

Electromagnetic compatibility: The sensor must correctly be grounded, a shielded cable is recommended.

Cleaning of the laser window

- 1) dry cleaning with a soft brush
- 2) cleaning with a dry, soft, antistatic cloth
- 3) wet cleaning with clear water, approx. 30 degree Celsius, if necessary with a little mild soap.

Please do NOT use window cleaner!!

TECHNICAL DATA

		LAV-8-420-IO	LAV-50-420-IO
Measurement range	[m]	0.2...8.0 (target: white 90%) *	0.2...50.0
Absolute accuracy	[mm]	±25	±25
Repeatability	[mm]	<5	< 5
Beam divergence	[mrad]	1	1
Pulse length	[ns]	5	5
Repetition rate laser	[kHz]	250	250
Angle deviation	[°]	max. ±2	max. ±2
Laser class		2	2
Diameter of light spot	[mm]	<10 at a distance of 8 m at 20°C	<50 at a distance of 50 m at 20°C
Ambient light limit	[Lux]	50000	50000
Temperature influence	[mm/K]	typ. ≤0.25	typ. ≤0.25
MTTF	[a]	200	200
Mission time (T ₁₀)	[a]	10	10
Operating voltage	[VDC]	10...30 VDC / when operating in IO-Link mode: 18...30 V	10...30 VDC / when operating in IO-Link mode: 18...30 V
Ripple		10% within the supply tolerance	10% within the supply tolerance
No-load supply current		≤70 mA / 24 VDC	≤70 mA / 24 VDC
Time delay before availability	[s]	2	2
Operating temperature	[°C]	-30...50	-30...50
Protection class		IP65	IP65
Interface		IO-Link (V1.0)	IO-Link (V1.0)
Signal output		Push-pull	Push-pull
Switching voltage	[VDC]	30	30
Switching current	[mA]	100	100
Measurement output		4...20 mA	4...20 mA
Switching frequency	[Hz]	50	50
Response time output	[ms]	10	10
Connection		4-pin, M12 x 1 connector (cable output on request)	4-pin, M12 x 1 connector (cable output on request)
Housing material		Plastics ABS	Plastics ABS
Weight	[g]	90	90
EMC		EMC Directive 2004/108/EC	EMC Directive 2004/108/EC
UL approval		cULus Listed, Class 2 Power Source, Type 1 enclosure	cULus Listed, Class 2 Power Source, Type 1 enclosure

* gray target (18%) : range approx. 3.5 m / black target (10%): range approx. 2.5 m

ELECTRICAL CONNECTION

Electrical connection LAV

PIN	Function
1	+ U _B
2	Teach-in Q2
3	0 V
4	C / Teach-in Q2

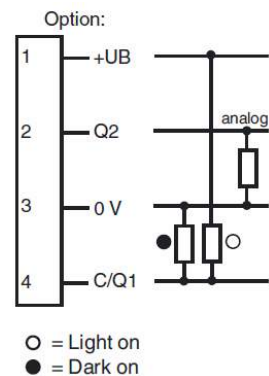
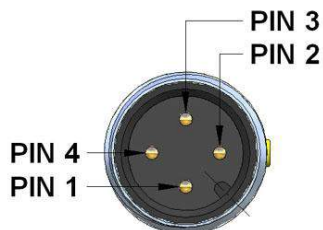

TECHNICAL DRAWING

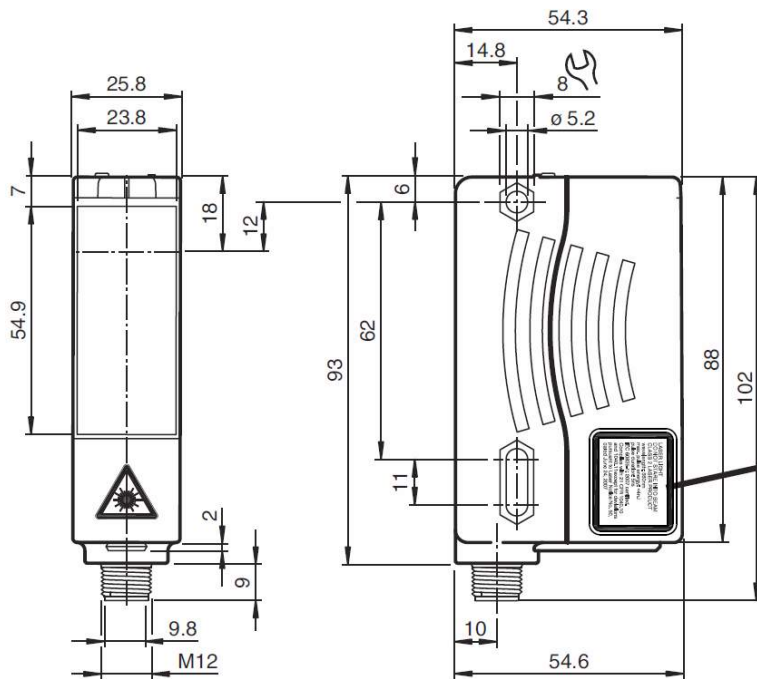

LASER LIGHT
 DO NOT STARE INTO BEAM
 CLASS 2 LASER PRODUCT
 wavelength: 660nm
 max. pulse energy: <4nJ
 pulse duration: 5ns
 IEC 60825-1: 2007 certified.
 Complies with 21 CFR 1040.10
 and 1040.11 except for deviations
 pursuant to Laser Notice No. 50,
 dated June 24, 2007

INDICATORS

- | | | |
|---|--------------------|--------|
| 1 | Operating displays | green |
| 2 | Signal display | yellow |
| 3 | Teach-In button | |
| 4 | Mode rotary switch | |
| 5 | Laser output | |

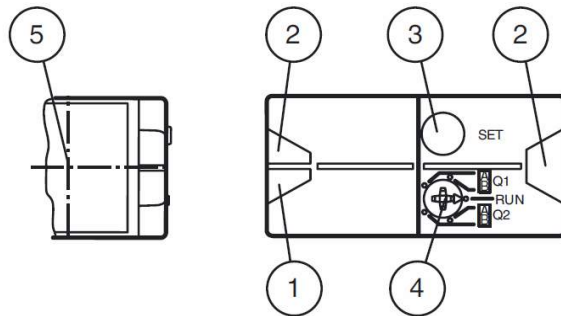

TEACH-IN GUIDE

Teach-In:

You can use the rotary switch to select the relevant switching threshold A and/or B for teaching in for switching output Q1. The yellow LEDs indicate the current state of the selected output. To store a switching threshold (distance measured value), press and hold the "SET" button until the yellow and green LEDs flash in phase (approx. 2 s). Teach-In starts when the "SET" button is released.

Successful Teach-In is indicated by alternating flashing (2.5 Hz) of the yellow and green LEDs. An unsuccessful Teach-In is indicated by rapidly alternating flashing (8 Hz) of the yellow and green LEDs. After an unsuccessful Teach-In, the sensor continues to operate with the previous valid setting after the relevant visual fault signal is issued.

Different switching modes can be defined by teaching in the relevant distance measured values for the switching thresholds A and B: (see diagram on the right).

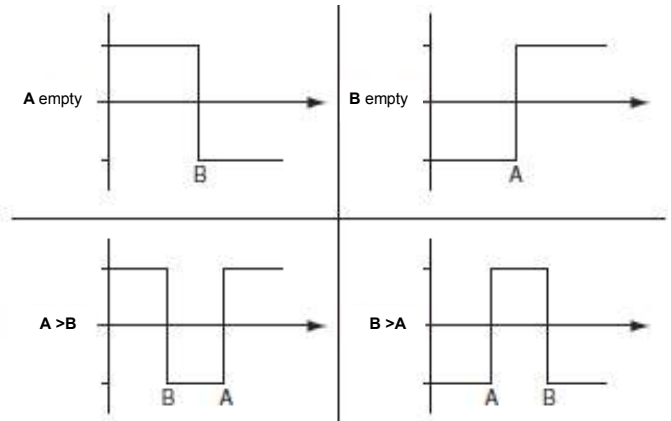

Every taught-in switching threshold can be re-taught (overwritten) by pressing the SET button again. Pressing and holding the "SET" button for > 5 s completely deletes the taught-in value. The yellow and green LEDs go out simultaneously to indicate that this procedure has been completed. Minimum and maximum values for the analog output Q2 are taught in in the same way as those for the switching output:

The following values apply:

- A = 4 mA
- B = 20 mA

This provides three different options for operation:

A < B -> rising slope

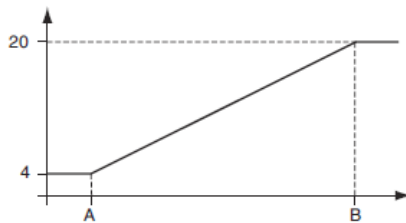

A > B -> falling slope

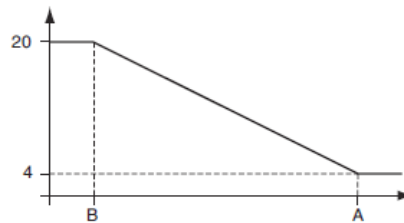

A empty -> zero start point

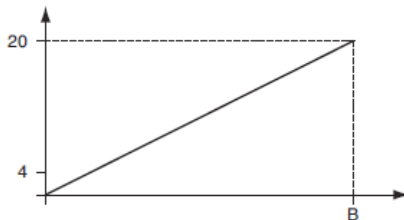

Reset to default settings:

Factory setting for switching output Q1:

Switching output inactive

Factory setting for analog output Q2:

- A = 200 mm
- B = 5000 mm

Value B cannot be deleted

The "zero start point" operating mode can be obtained by deleting value A

Set the rotary switch to the "RUN" position

Press and hold the "SET" button until the yellow and green LEDs stop flashing in phase (approx. 10 s)

When the green LED lights up continuously, the procedure is complete.

Note!

The difference in the taught-in distance measured values for switching thresholds A and B must be greater than 20 mm.

If the difference in the taught-in measured values is the same as or smaller than the set switching hysteresis, the sensor will visually signal an unsuccessful Teach-In. The last distance measured value that was taught in will not be adopted by the sensor. Select a new distance measured value for switching threshold A or B with a greater difference between the switching thresholds.

Teach in this distance measured value on the sensor again. Switching threshold A can be deleted or set to a value of zero. (E.g., when setting the "zero start point" curve). However, switching threshold B can neither be deleted nor set to a value of zero.

ORDER CODE

LAV-8-420-IO	Range 0.2...8.0 m
LAV-50-420-IO	Range 0.2...50.0 m

ACCESSORIES

Cable with mating connector M12, 4 poles, shielded, IP67

K4P2M-S-M12	2 m, straight connector
K4P5M-S-M12	5 m, straight connector
K4P10M-S-M12	10 m, straight connector
K4P2M-SW-M12	2 m, angular connector
K4P5M-SW-M12	5 m, angular connector
K4P10M-SW-M12	10 m, angular connector

Mating Connector M12, 4 poles, shielded, IP67

D4-G-M12-S	straight, M12 for self assembly
D4-W-M12-S	angular, M12 for self assembly

Digital display 1 channel, 0...10V/4...20 mA

PAXP000B	1 channel, supply: 85 to 250 VAC
PAXP001B	1 channel, supply: 11...36 VDC/24 VAC

Digital display 2 channels, 0...10V/4...20 mA

PAXDP00B	2 channels, supply: 85 to 250 VAC
PAXDP01B	2 channels, supply: 11...36 VDC/24 VAC

For further information please see the separate PAX data sheet



General safety instructions

Attention radiation laser.

Do not stare into beam.

Do not point the laser beam towards someone's eye.

It is recommended to stop the beam by a matte object or matte metal shield.

Laser regulations require the power to the sensor be switched off when turning off the whole system this sensor is part off.

Subject to change without prior notice.

WayCon Positionsmesstechnik GmbH

email: info@waycon.de
internet: www.waycon.de

Head Office

Mehlbeerenstr. 4
82024 Taufkirchen
Tel. +49 (0)89 67 97 13-0
Fax +49 (0)89 67 97 13-250

Office Köln

Auf der Pehle 1
50321 Brühl
Tel. +49 (0)2232 56 79 44
Fax +49 (0)2232 56 79 45